

Hexagon Geospatial Solutions Division (GSD)

The Z/I DMC II Imaging Revolution

Klaus Neumann Product Manager Sensor Systems

PhoWo 2011

Klaus Neumann

6. September 2011

The power to see



- when it has to be right



DMC II Camera System



PhoWo 2011

Klaus Neumann

6. September 2011

The power to see



- when it has to be right



DMC II Camera Design

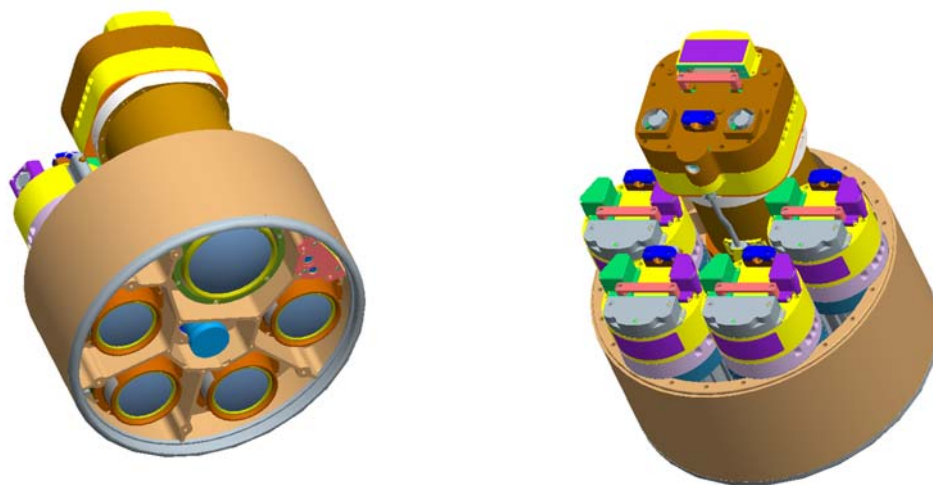

DMC II Sensor Design

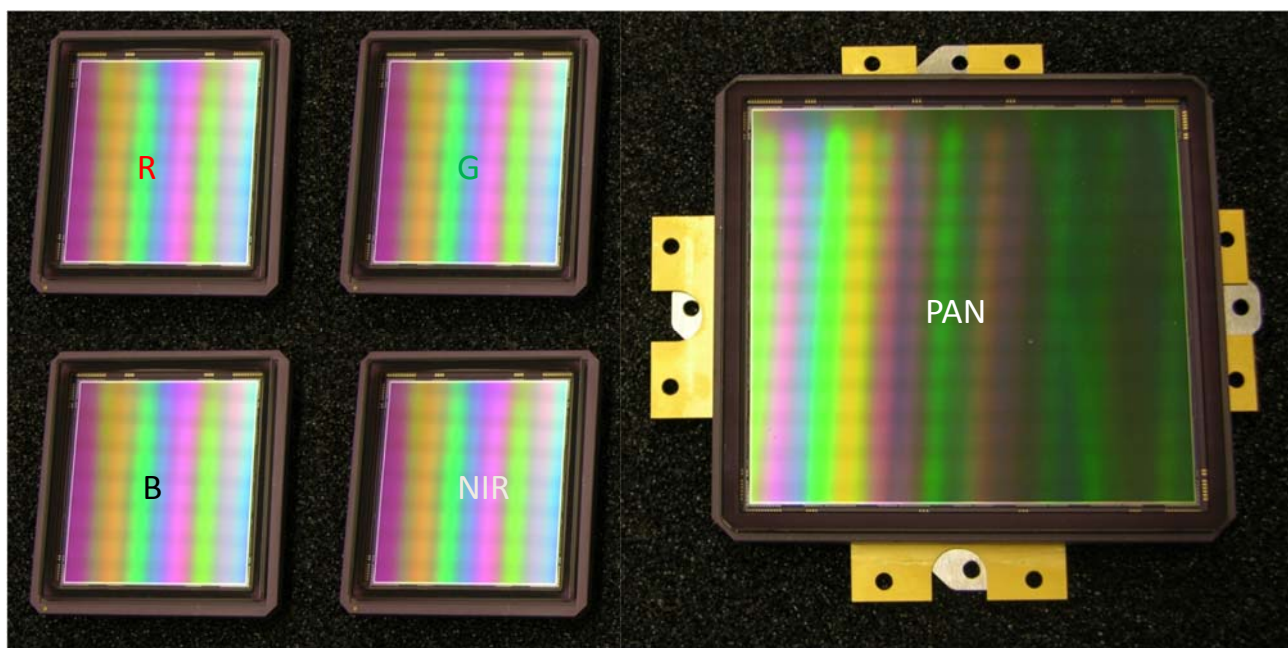

DMC II Sensor Design



PhoWo 2011

Klaus Neumann

6. September 2011

The power to see 

- when it has to be right



DMC II Sensor Design

- CCD pixel size: 5.6 μm and 7.2 μm
- Focal length: 92 mm and 112 mm
- Field of view across track: 45.5° and 50.7°
- Field of view along track: 38.6° and 47.3°

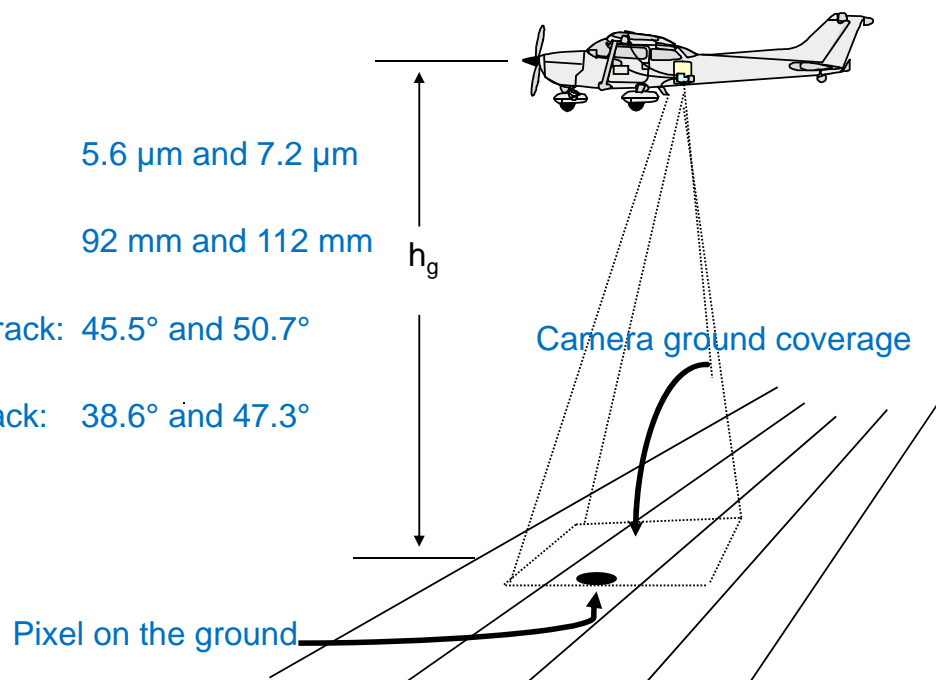

PhoWo 2011

Klaus Neumann

6. September 2011

The power to see 

- when it has to be right



DMC II Footprint & AGL – Ideal For Urban Mapping

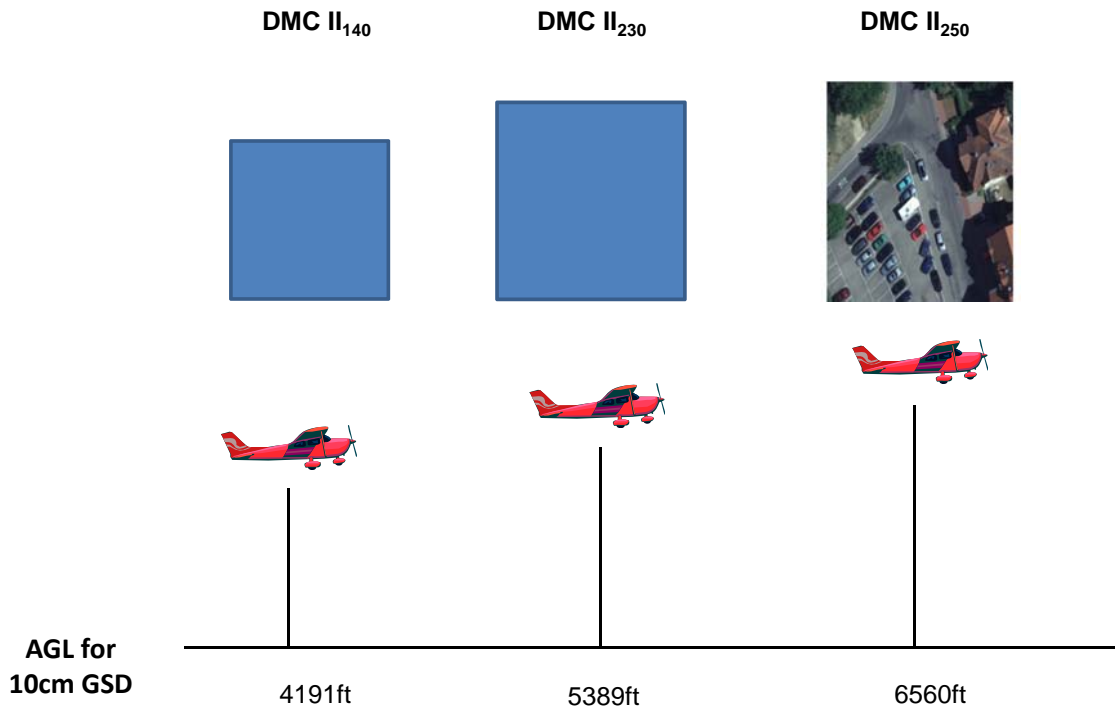

PhoWo 2011

Klaus Neumann

6. September 2011

The power to see



- when it has to be right



DMC II Sensor Design

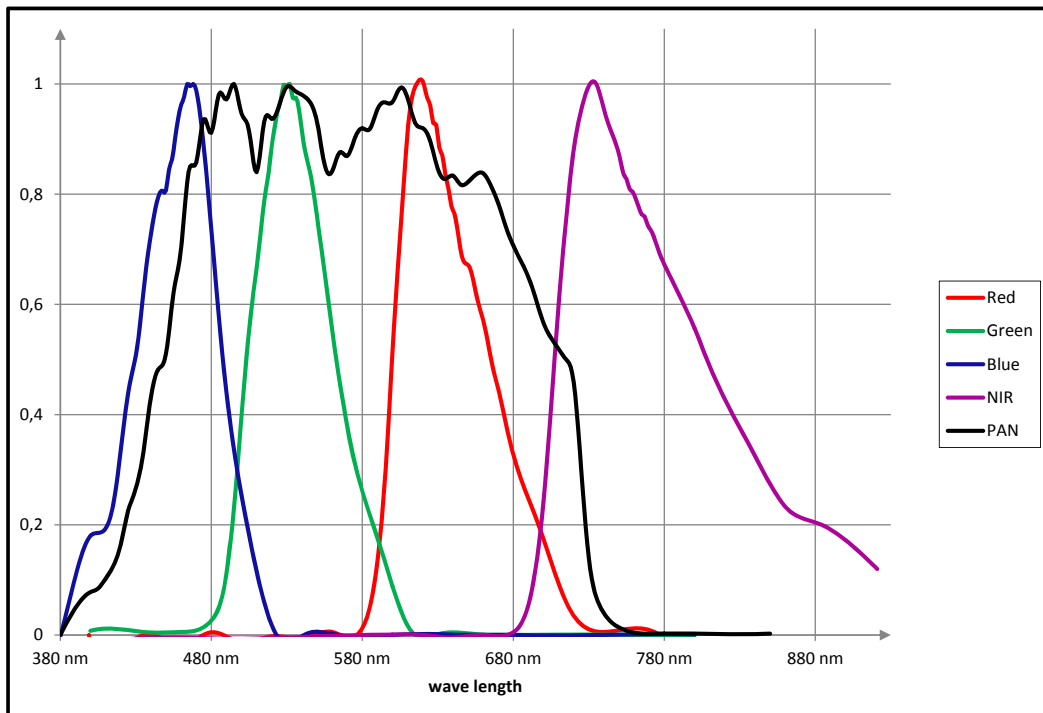

PhoWo 2011

Klaus Neumann

6. September 2011

The power to see



- when it has to be right



DMC II Sensor Design

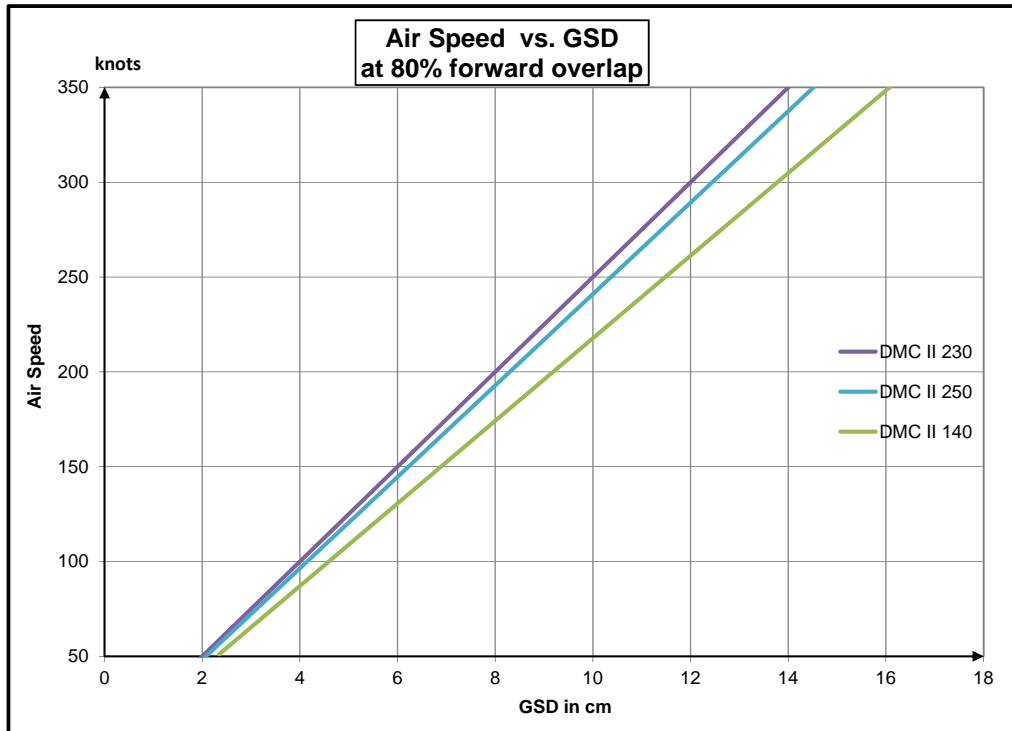

DMC II Camera Family

Feature	DMC II 140	DMC II 230	DMC II 250
pixel across track	12096	15552	16768
pixel along track	11200	14144	14016
FoV across track	50,7 °	50,7 °	45,5 °
FoV along track	47,3 °	46,6 °	38,6 °
focal length	92 mm	92 mm	112 mm
GSD@500m	3,9 cm	3,0 cm	2,5 cm
B/H	0,35	0,34	0,28
accuracy X,Y	0.5 GSD	0.5 GSD	0.5 GSD
accuracy vertical	0.7 GSD	0.7 GSD	0.7 GSD
pixel size	7,2 µm	5,6 µm	5,6 µm
number of camera heads	5	5	5
PAN : Color Resolution	1:2	1:2,6	1:3,2
frame rate	2,2 sec	2,3 sec	2,3 sec
color channels	R,G,B, NIR	R,G,B, NIR	R,G,B, NIR
resolution per pixel	14 bit	14 bit	14 bit
FMC	yes	yes	yes
CCD dynamic range	>70 dB	>70 dB	>70 dB
onboard storage	1.5 Tbyte	2 Tbyte	2 Tbyte
weight	66 kg	66 kg	66 kg
power consumption	350 W	350 W	350 W
Altitude non pressurized	8000 m	8000 m	8000 m
operating temperature	-20°C to +40°C	-20°C to +40°C	-20°C to +40°C



DMC II Sensor Design

CCD cover

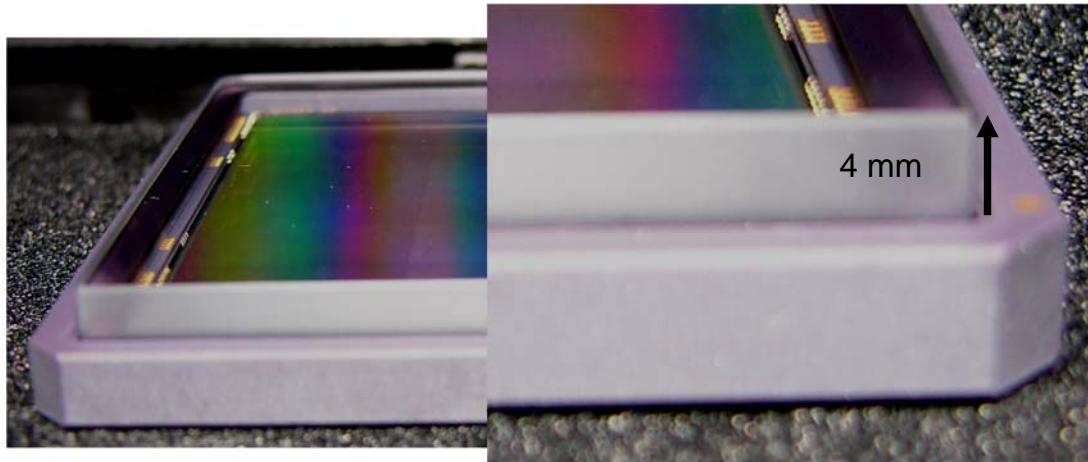

DMC II Sensor Design

Thickness 2 mm

Deckglasdicke: 2 mm

z. B. max. Flächenkipfung um z-Achse: $0^{\circ} 16' 07''$

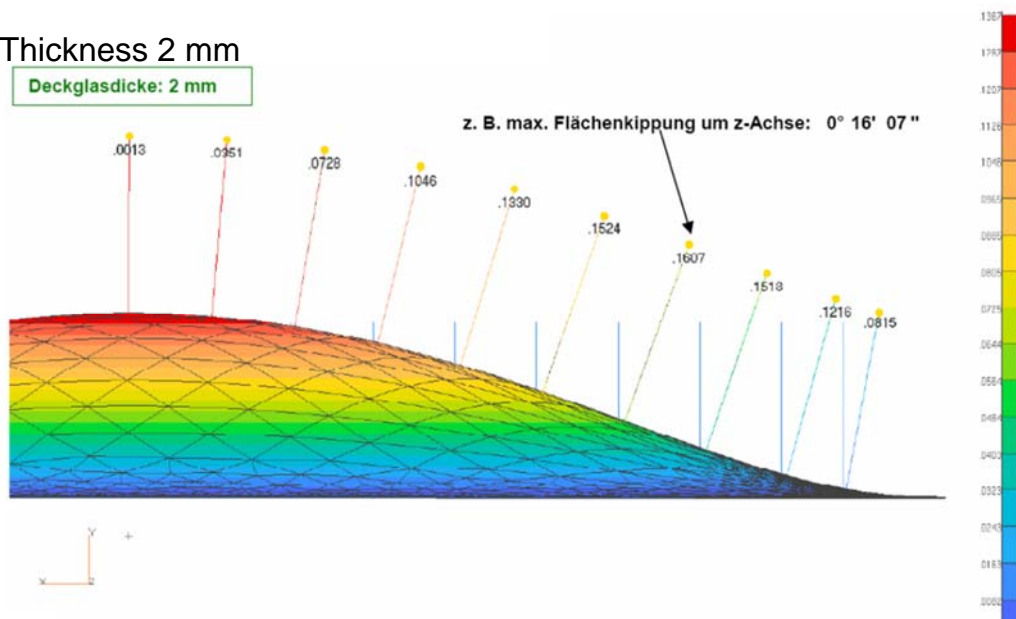

DMC II Sensor Design

Thickness 4 mm

Deckglasdicke: 4 mm

z. B. max. Flächenkipfung um z-Achse: 0° 02' 27''

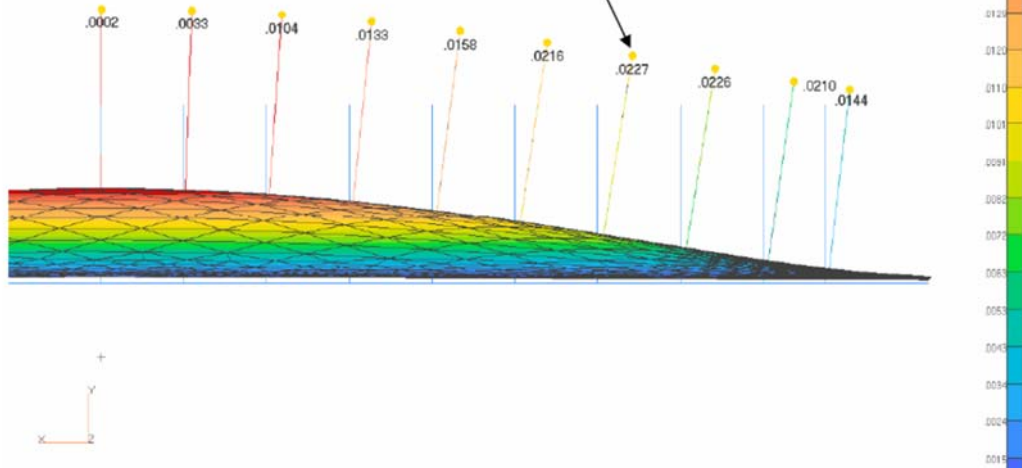

DMC II Sensor Design

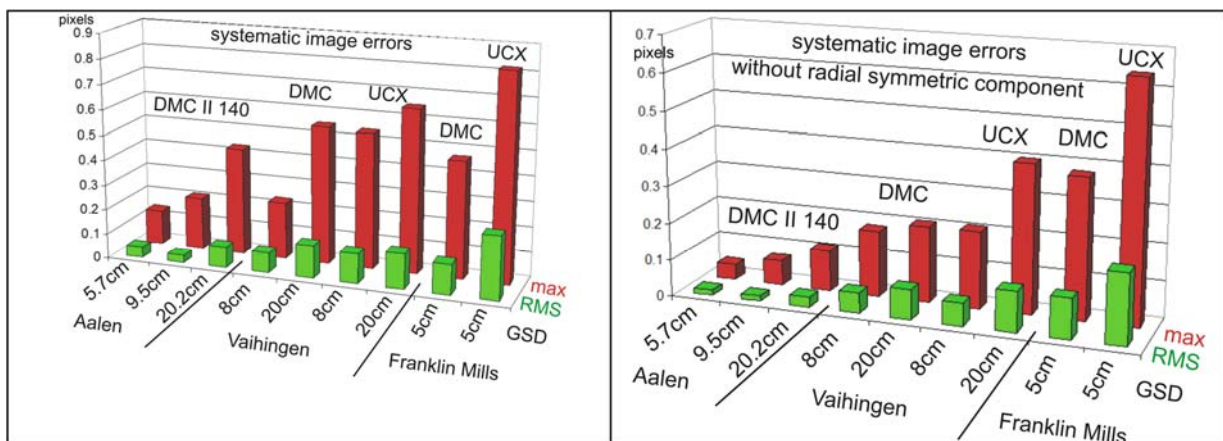

Root mean square and maximal errors for various cameras

DMC II Sensor Design

Total effect of systematic image errors for DMC II 140

without radial symmetric component			with radial symmetric component	
GSD	RMS	Max	RMS	Max
5.7cm	0.3 μm	1.3 μm	0.1 μm	0.3 μm
9.5cm	0.2 μm	1.5 μm	0.1 μm	0.5 μm
20.2cm	0.6 μm	3.1 μm	0.2 μm	0.8 μm

DMC II customer base

More than 20 DMC II sold since 2010
130 DMC & DMC II in operation worldwide

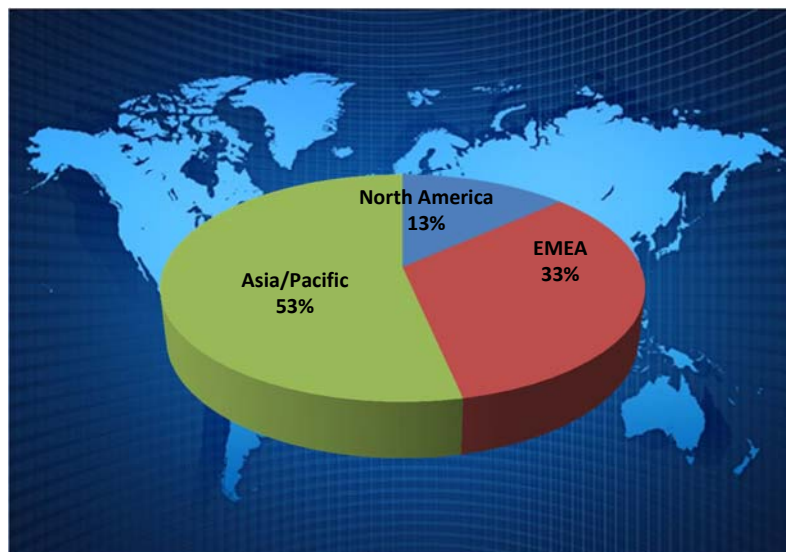

... the most complete professional airborne sensor portfolio



Z/I DMC II
Frame

Imaging



Leica RCD
Frame

Imaging



Leica ADS
Pushbroom

Imaging



Leica ALS

LIDAR

PhoWo 2011

Klaus Neumann

6. September 2011

The power to see



- when it has to be right



17

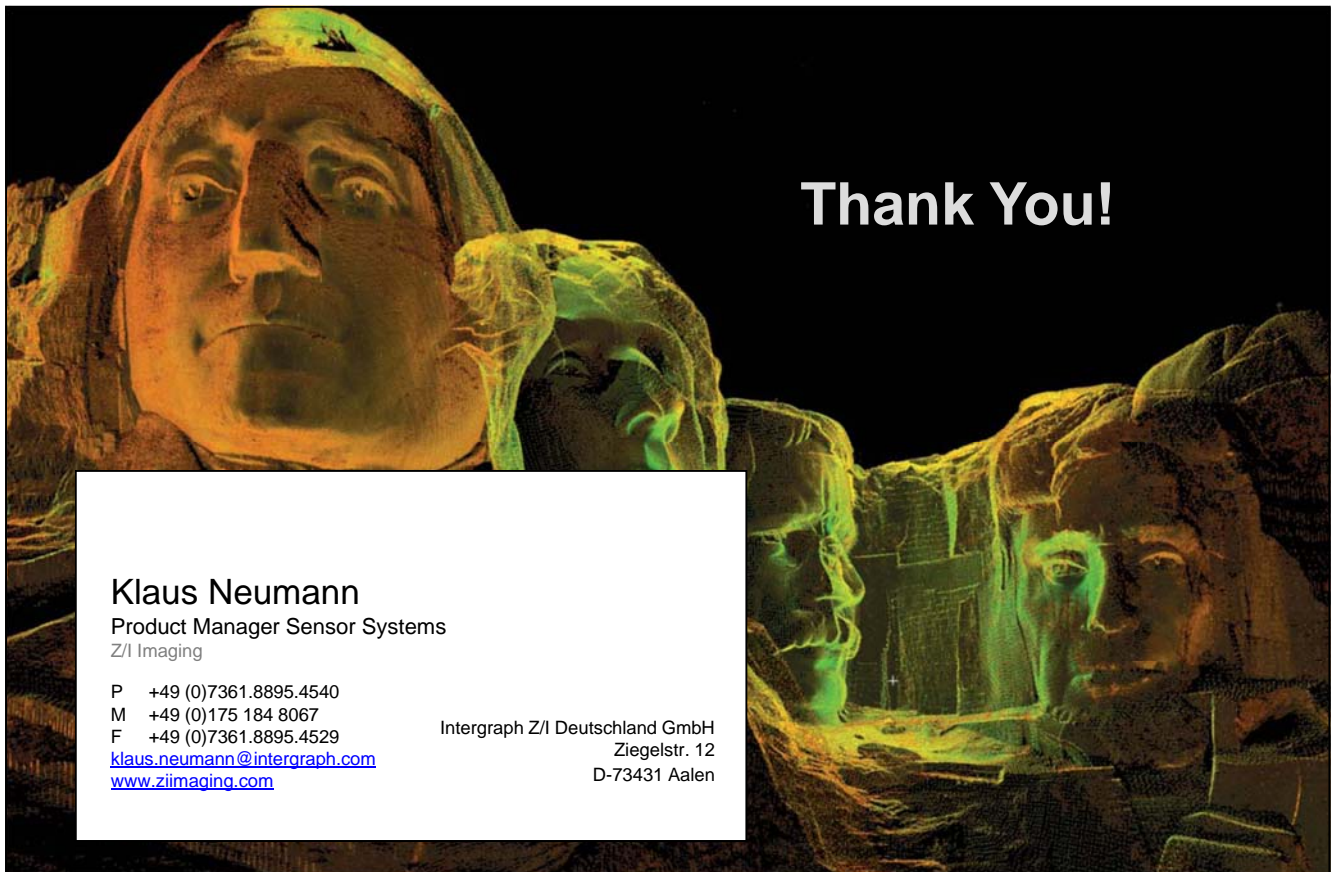

Thank You!

Klaus Neumann

Product Manager Sensor Systems
Z/I Imaging

P +49 (0)7361.8895.4540

M +49 (0)175 184 8067

F +49 (0)7361.8895.4529

klaus.neumann@intergraph.com

www.ziimaging.com

Intergraph Z/I Deutschland GmbH
Ziegelstr. 12
D-73431 Aalen

PhoWo 2011

Klaus Neumann

6. September 2011

The power to see



- when it has to be right

